



Programmable Logic Controller with Open PLC Architecture **PLC-DPLC series**



■ Features

- Cost-effective Programmable Logic Controller
- Scalable through a wide range of compatible expansion modules
- Supports MODBus Communication protocol
- Easy DIN rail installation
- Compliant with the IEC 61131-3 international PLC standard

■ Applications

- Industrial Automation
- SMT Production Line Automation
- Smart Agriculture
- Elevator Control
- Building Automation Systems

■ Description

The PLC-DPLC is a new-generation Programmable Logic Controller manufactured by MEAN WELL. Its highly modular design allows users to customize functionality by adding expansion modules as needed. It is programmed with the OpenPLC Editor, which offers diverse function libraries for easy calling. This platform provides excellent versatility, program portability, and reusability, enabling rapid project deployment and simplified equipment maintenance. With support for the Modbus communication interface, it enables remote monitoring of on-site equipment and seamless integration with other devices.

■ Model Encoding

PLC - DPLC - 32 M T

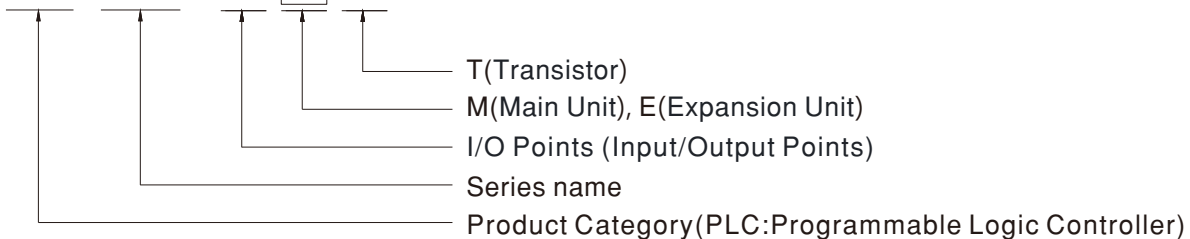



Programmable Logic Controller with Open PLC Architecture **PLC-DPLC series**

| SPECIFICATION | PLC-DPLC-32MT | PLC-DPLC-32ET | |
|-------------------------------|--|--|---|
| POWER SUPPLY | | | |
| RATED VOLTAGE | 20.4~28.8VDC | | |
| POWER | 15W | | |
| ENVIRONMENT | | | |
| WORKING TEMP. | 0 ~ +55°C | | |
| STORAGE TEMP. | -40 ~ +70°C | | |
| AMBIENT HUMIDITY | 5 ~ 95% RH non-condensing | | |
| VIBRATION | 5 ~ 150Hz, 2G 12min./1cycle, each along X, Y, Z axes according to EN50090-2-2 | | |
| FUNCTION | | | |
| DIGITAL INPUT | 12 CHANNEL + 4 HIGH SPEED COUNTER | 16 CHANNEL | |
| ANALOG INPUT | 2 CHANNEL | 4 CHANNEL | |
| DIGITAL OUTPUT | 12 CHANNEL + 4 PWM | | |
| CLOCK/CALENDAR | 7 DAYS | ----- | |
| PROGRAM LANGUAGE | IEC 61131-3(LD, FBD, IL, ST, SFC) | ----- | |
| SAFETY & EMC | 512K BYTES | ----- | |
| PROGRAM CAPACITY | MODBUS | ----- | |
| COMMUNICATION PROTOCOL | | | |
| SAFETY & STANDRDS | EN 61010-1:2010/A1:2019, EN IEC 61010-2-201:201 | | |
| WITHSTAND VOLTAGE | 500 VAC FOR 1 MINUTE DIGIT INPUT AND OUTPUT TERMINALS POWER AND DIGIT INPUT FUNCTIONAL GROUND TERMINALS POWER AND OUTPUT FUNCTIONAL GROUND TERMINALS | | |
| ISOLATION RESISTANCE | TEST VOLTAGE: 500 VDC 100 MΩ OR MORE DIGIT INPUT AND OUTPUT TERMINALS POWER AND DIGIT INPUT FUNCTIONAL GROUND TERMINALS POWER AND OUTPUT FUNCTIONAL GROUND TERMINALS | | |
| EMC EMISSION | Parameter | Standard | Test Level / Note |
| | Conducted | IEC61131-2 | Class A |
| | Radiated | IEC61131-2 | Class A |
| EMC IMMUNITY | IEC61131-2 | | |
| | Parameter | Standard | Test Level / Note |
| | ESD | IEC61131-2 | Level 3,8KV air;Level 2,4KV,contact |
| | Radiated | IEC61131-2 | Level 3,3V/m |
| | EFT / Burst | IEC61131-2 | Level 3,2KV |
| | Surge | IEC61131-2 | Level1,1KV/Line-Earth;Level 2,1KV/Line-Line |
| | Conducted | IEC61131-2 | Level 3,10V |
| Magnetic Field | IEC61131-2 | Level 4,30A/m | |
| OTHERS | | | |
| MTBF | 200.9K hrs min. Telcordia SR-332 (Bellcore) ; 78.6K hrs min. MIL-HDBK-217F (25°C) | 227.0K hrs min. Telcordia SR-332 (Bellcore) ; 83.3K hrs min. MIL-HDBK-217F (25°C) | |
| DIMENSION | 144*90*60.3mm (L*W*H) | | 144*90*58.3mm (L*W*H) |
| PACKING | 0.36Kg; 30pcs/12Kg/1.35CUFT | | |



| DIGITAL INPUT SPECIFICATION | | PLC-DPLC-32MT | PLC-DPLC-32ET |
|-----------------------------|----------|---|---|
| NUMBER OF DIGITAL INPUTS | | 16(4 HIGH SPEED COUNTER) | 16 |
| INPUT FORM | | SOURCE/SINK | |
| INPUT CURRENT | | 2.1mA | |
| RATED VALUE | | 24VDC | |
| ACTION LEVEL | OFF → ON | >15VDC | |
| | ON → OFF | <5VDC | |
| HIGH SPEED COUNTER | | I1.0~I1.3(100KHz/4 groups、200KHz/single group) | |
| RESPONSE TIME | | I1.0~I1.3 (HIGH SPEED COUNTER): 5μs/4 groups, 2.5μs/single group I0.0~I0.7, I1.4~I1.7(DIGITAL INPUT): One scan cycle (10ms~100ms depending on the number of expansion units) | I0.0~I1.7: One scan cycle (10ms~100ms depending on the number of expansion units) |

| ANALOG INPUT SPECIFICATION | | PLC-DPLC-32MT | PLC-DPLC-32ET |
|----------------------------|--|---------------|---------------|
| NUMBER OF ANALOG INPUTS | | 2 | 4 |
| INPUT RANGES | | 0 ~ +10VDC | |
| INPUT RESISTANCE | | ≥100KΩ | |
| RESOLUTION | | 12BIT | |

| DIGITAL OUTPUT SPECIFICATION | | PLC-DPLC-32MT | PLC-DPLC-32ET |
|------------------------------|--|--------------------------|---------------|
| NUMBER OF DIGITAL OUTPUT | | 16(4 HIGH-SPEED OUTPUTS) | |
| RATED VALUE | | 24VDC | |
| MAXIMUM LOAD | | 0.5A | |
| HIGH SPEED OUTPUT | | Q0.0~Q0.3(100KHz) | |

■ Mechanical Specification

※ PLC-DPLC-32MT

Case No.DPLC

(Unit:mm, tolerance ± 1mm)

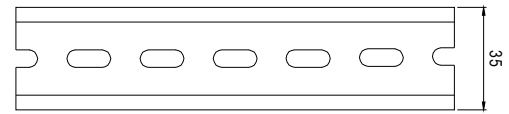
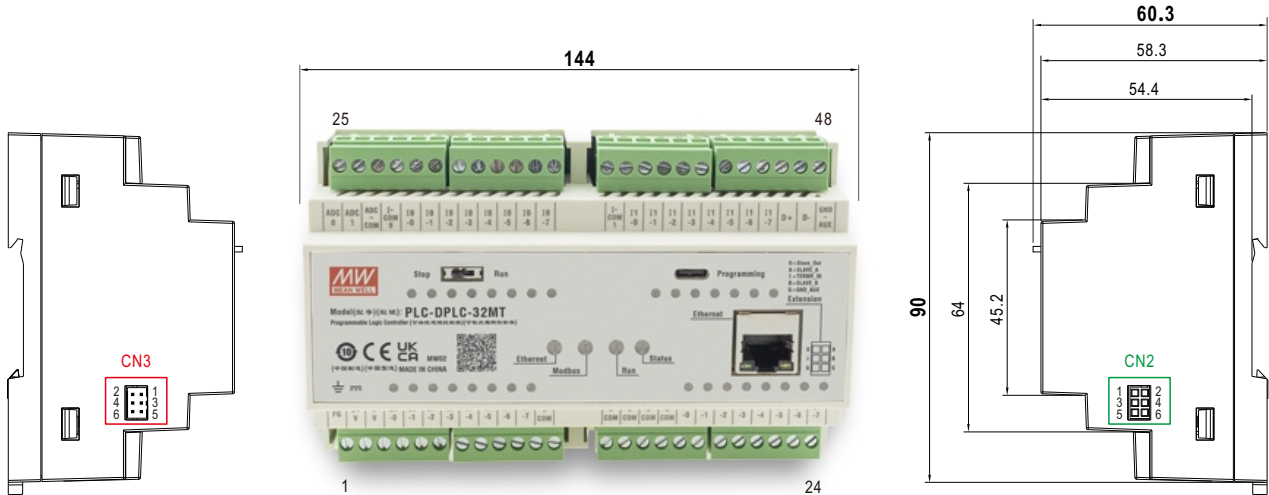

ADMISSIBLE DIN-RAIL: TS35/7.5 OR TS35/15

※ LED Status Indicators & Corresponding Signal at Function Pins

| LED | Description |
|----------|-----------------------|
| STATUS | System status |
| RUN | RUN/STOP |
| MOD | MODBus status |
| ETHERNET | Ethernet status |
| I | Digital input status |
| Q | Digital output status |

※ Control Pin No. Assignment(CN2) : Samtec SSW-103-02-G-D-RA or equivalent



Mating Connectors Samtec MTLW-103-10-G-D-385 or equivalent

| Pin No. | Function | Description |
|---------|-----------|---|
| 1 | DA | For Master/Slave model: Data line used in Master/Slave interface |
| 2 | Slave_OUT | For Slave model: Data line used in Slave Serial Number interface |
| 3 | DB | For Master/Slave model: Data line used in Master/Slave interface |
| 4 | TR_IN | For Slave model: Data line used in Slave Termination Resistor interface |
| 5,6 | GND_AUX | Isolated signal, referenced to GND-AUX for Master/Slave communication |

※ Control Pin No. Assignment(CN3) : HRS DF11-6DP-2DS or equivalent(When multiple hosts are connected in parallel for communication, a short PIN must be connected to the CN3 port of the first and last host.)



| | |
|----------------|----------------------------|
| Mating Housing | HRS DF11-6DS or equivalent |
| Terminal | HRS DF11-6SC or equivalent |

| Pin No. | Function | Description |
|---------|----------|---|
| 1 | TR+ | Line used in Slave Termination Resistor interface |
| 2 | TR- | Line used in Slave Termination Resistor interface |
| 3~6 | NC | ----- |

※ IN/OUT Connector Pin No. Assignment :

| Pin No. | Function | Description |
|--------------|----------------------|---|
| 1 | FG | Power supply frame ground |
| 2 | +24V | Power supply 24V |
| 3 | 0V | Power supply 0V |
| 4~7 | Q0.0~Q0.3 | PWM output |
| 8~11, 17~24 | Q0.4~Q1.7 | Digital output |
| 12~16 | Q-COM | Common for Q |
| 25 | ADC0 | Analog input 0 |
| 26 | ADC1 | Analog input 1 |
| 27 | ADC-COM | Analog common |
| 28 | I-COM0 | Common for I0.0~I0.7 |
| 29~36, 42~45 | I0.0~I0.7; I1.4~I1.7 | Digital Input |
| 37 | I-COM1 | Common for I1.0~I1.7 |
| 38~41 | I1.0~I1.3 | High speed counter |
| 46 | D+ | For MODBus model: Data line used in MODBus interface |
| 47 | D- | For MODBus model: Data line used in MODBus interface |
| 48 | GND-AUX | Isolated signal, referenced to GND-AUX for MODBus communication |

■ Mechanical Specification

※ PLC-DPLC-32ET

Case No.DPLC

(Unit:mm, tolerance ± 1mm)

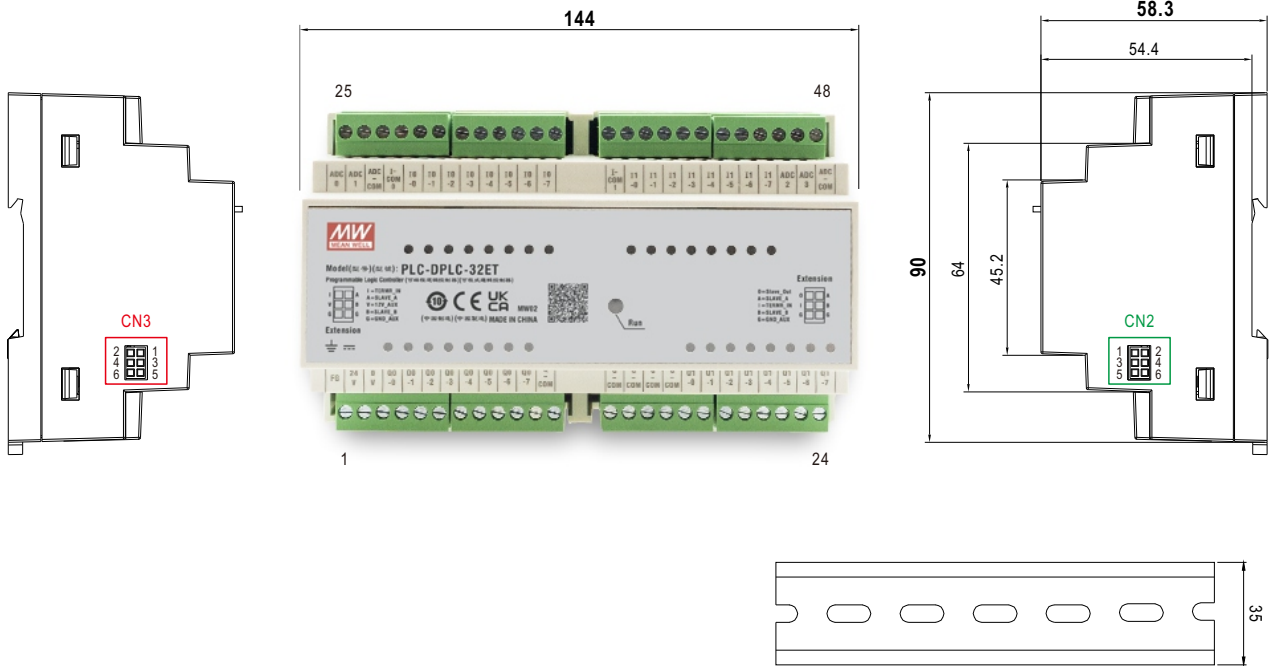

ADMISSIBLE DIN-RAIL:TS35/7.5 OR TS35/15

※ LED Status Indicators & Corresponding Signal at Function Pins

| LED | Description |
|-----|-----------------------|
| RUN | RUN/STOP |
| I | Digital input status |
| Q | Digital output status |

※ Control Pin No. Assignment(CN2) : Samtec SSW-103-02-G-D-RA or equivalent



Mating Connectors | Samtec MTLW-103-10-G-D-385 or equivalent

| Pin No. | Function | Description |
|---------|-----------|---|
| 1 | DA | For Master/Slave model: Data line used in Master/Slave interface |
| 2 | Slave_OUT | For Slave model: Data line used in Slave Serial Number interface |
| 3 | DB | For Master/Slave model: Data line used in Master/Slave interface |
| 4 | TR_IN | For Slave model: Data line used in Slave Termination Resistor interface |
| 5,6 | GND_AUX | Isolated signal, referenced to GND-AUX for Master/Slave communication |

※ Control Pin No. Assignment(CN3) : Samtec SSW-103-02-G-D-RA or equivalent



Mating Connectors | Samtec MTLW-103-10-G-D-385 or equivalent

| Pin No. | Function | Description |
|---------|----------|---|
| 1 | DA | For Master/Slave model: Data line used in Master/Slave interface |
| 2 | Slave_IN | For Slave model: Data line used in Slave Serial Number interface |
| 3 | DB | For Master/Slave model: Data line used in Master/Slave interface |
| 4 | TR_OUT | For Slave model: Data line used in Slave Termination Resistor interface |
| 5,6 | GND_AUX | Isolated signal, referenced to GND-AUX for MODBus communication |

※ IN/OUT Connector Pin No. Assignment :

| Pin No. | Function | Description |
|--------------|-----------|---------------------------|
| 1 | FG | Power supply frame ground |
| 2 | +24V | Power supply 24V |
| 3 | 0V | Power supply 0V |
| 4~7 | Q0.0~Q0.3 | PWM output |
| 8~11, 17~24 | Q0.4~Q1.7 | Digital output |
| 12~16 | Q-COM | Common for Q |
| 25 | ADC0 | Analog input 0 |
| 26 | ADC1 | Analog input 1 |
| 27,48 | ADC-COM | Analog common |
| 28 | I-COM0 | Common for I0.0~I0.7 |
| 29~36, 38~45 | I0.0~I1.7 | Digital Input |
| 37 | I-COM1 | Common for I1.0~I1.7 |
| 46 | ADC2 | Analog input 2 |
| 47 | ADC3 | Analog input 3 |

■ Wiring Configuration

1. PWM/Digital Output Q
Q0.0-Q0.7 and Q1.0-Q1.7, Q_COM

Sinking Output Connection:

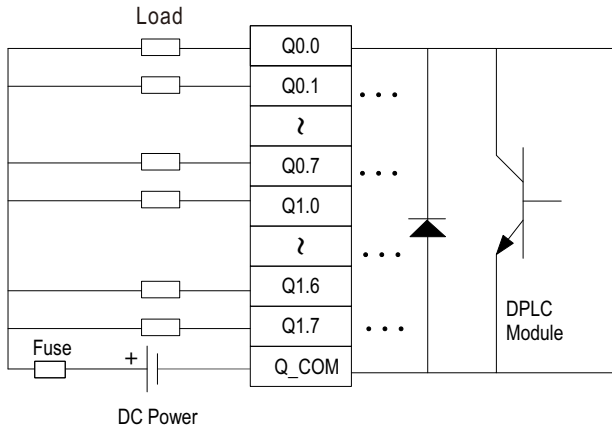

| Pin No. | Function | Description |
|------------|-----------|----------------|
| 4~7 | Q0.0~Q0.3 | PWM output |
| 8~11,17~24 | Q0.4~Q1.7 | Digital output |
| 12~16 | Q_COM | Common for Q |

2. PWM/Digital Input I
I0.0-I0.7 and I_COM0 ,I1.0-I1.7 and I_COM1

Sinking Input Connection:

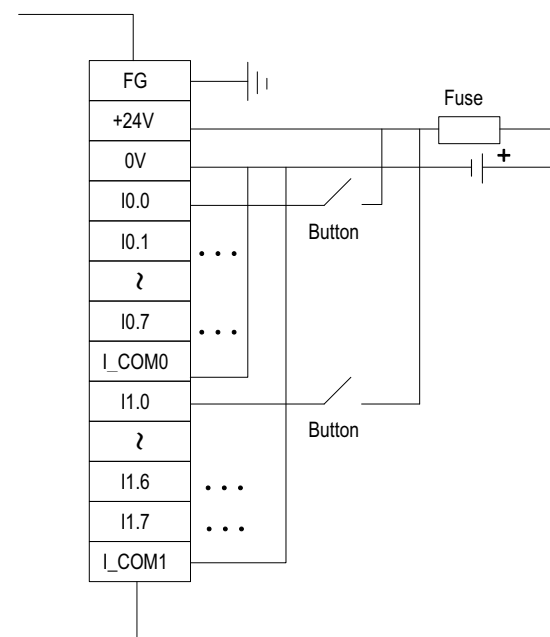

Source Input Connection:

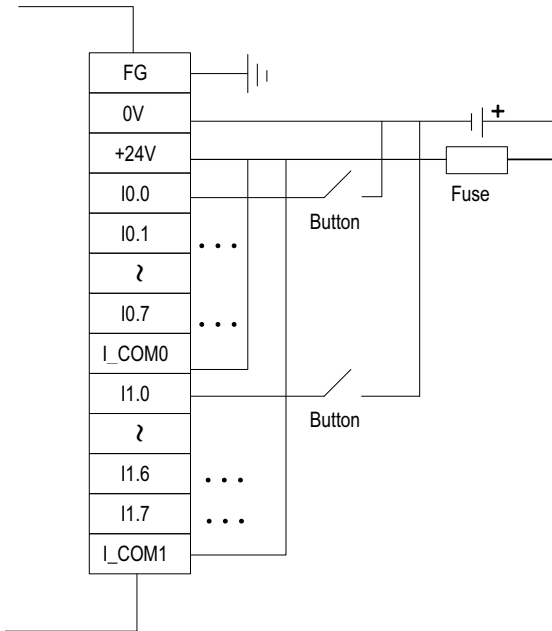

| Pin No. | Function | Description |
|---------|-----------|----------------------|
| 28 | I_COM0 | Common for I0.0~I0.7 |
| 29~36 | I0.0~I0.7 | Digital input |
| 37 | I_COM1 | Common for I1.0~I1.7 |
| 38~41 | I1.0~I1.3 | HSC input |
| 42~45 | I1.4~I1.7 | Digital input |

3. Analog Input ADC
ADC0,ADC1 and ADC_COM

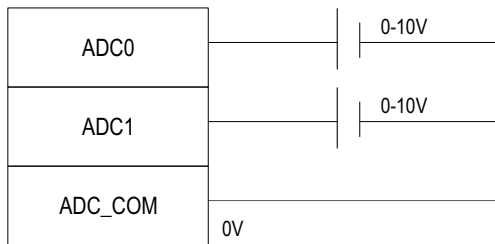

| Pin No. | Function | Description |
|---------|----------|----------------|
| 25 | ADC0 | Analog input 0 |
| 26 | ADC1 | Analog input 1 |
| 27 | ADC_COM | Analog common |

4.Supports MODBus communication

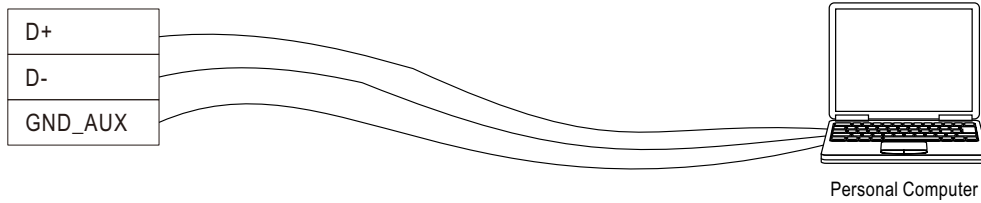

| Pin No. | Function | Description |
|---------|----------|---|
| 46 | D+ | For MODBus model: Data line used in MODBus interface |
| 47 | D- | For MODBus model: Data line used in MODBus interface |
| 48 | GND_AUX | Isolated signal, referenced to GND-AUX for MODBus communication |

5.Supports parallel function

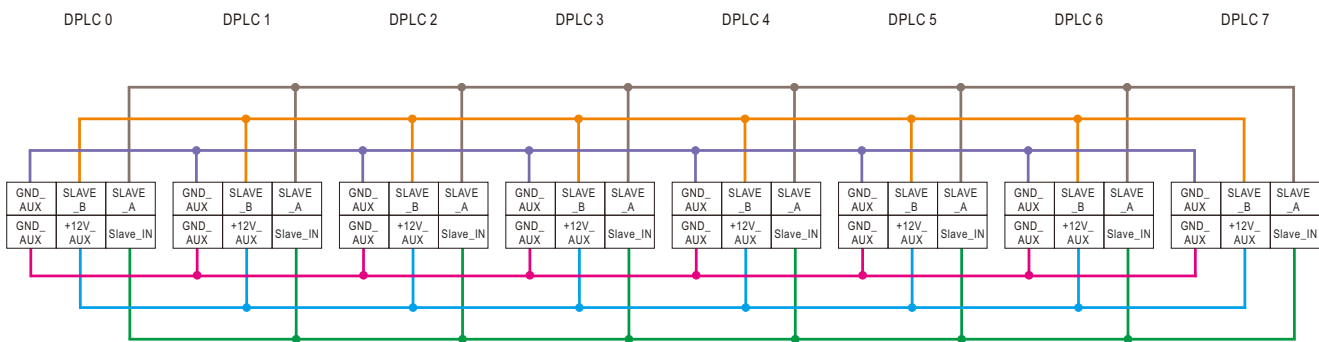

■ LED Status Indicators

Main Unit :

| Indicator | Green | Orange | Red |
|--------------------|--|--|-------------------------------------|
| Status Indicator | Light System Abnormal Flash Storage Operation | | |
| Run Indicator | Light Normal Operation Flash stop Status | Light Expansion Unit Disconnected Flash Programming Mode | Light Program Execution Abnormal |
| MODBus Indicator | Light Communicating | | Light Communication Abnormal |
| Ethernet Indicator | Light Communicating | | Light Communication Abnormal |

Expansion Unit :

| Indicator | Green | Orange | Red |
|---------------|-------------------------------------|---------------------------------------|------------------------------|
| Run Indicator | Light Address Judgment Completed | Light Address Judgment in Progress | Light Communication Abnormal |